

REV.	ECH. NO.	MODIFY. CONTENT	DATE
A		NEW	2011/10/31

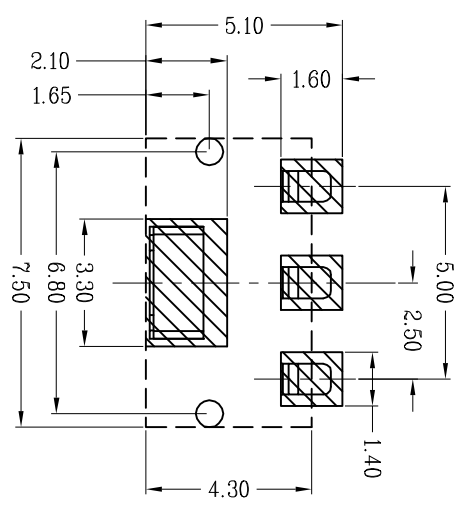

RECOMMENDED PCB LAYOUT  
TOLERANCE: ±0.05

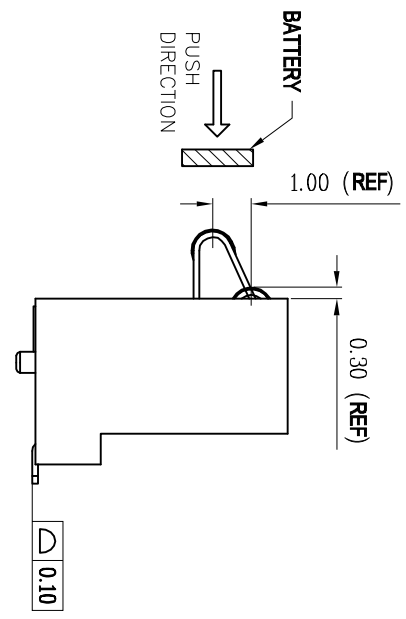
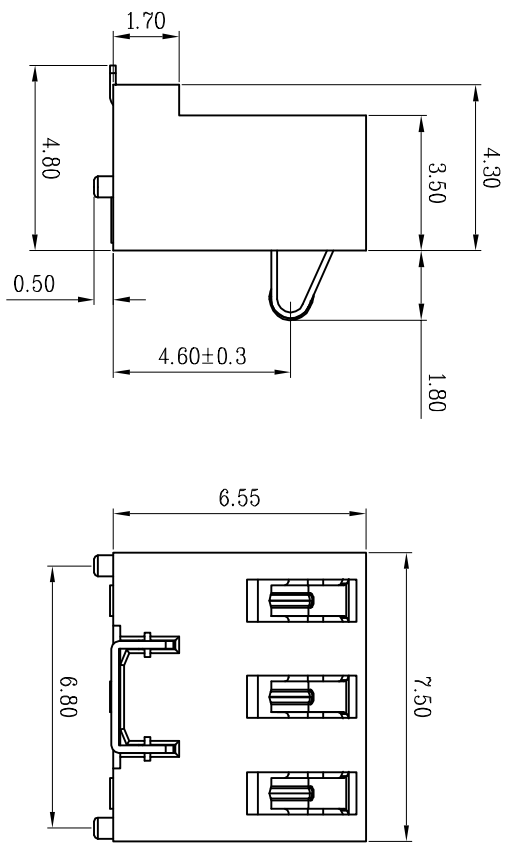
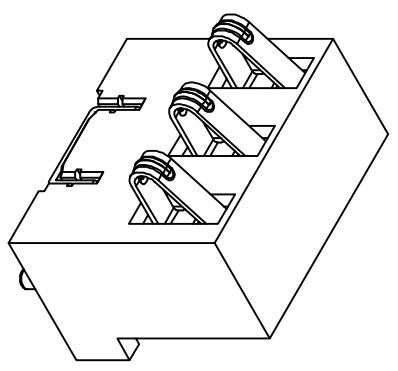
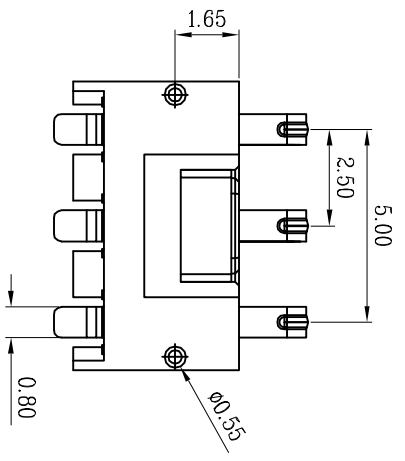

- NOTES:
- ELECTRICAL PERFORMANCES:
    - RATING CURRENT: 2A
    - RATING VOLTAGE: 100VAC
    - CONTACT RESISTANCE: 50  $\Omega$ m
    - INSULATION RESISTANCE: 1000  $\Omega$ m
    - Dielectric WITHSTANDING VOLTAGE: 500VAC FOR 1 MINUTE
  - MECHANICAL PERFORMANCE:
    - DURABILITY: 5000TIMES
    - NORMAL FORCE AT WORKING POSITION: 80gf Min.
    - OPERATION TEMPERATURE: -40° C ~ +85° C.

ITEM	DESCRIPTION	QUANTITY	MATERIAL	FINISH	REMARK
③	PAD	1	STAINLESS STEEL	Ni PLATING OVER ALL TIN PLATING OVER ALL	
②	CONTACT	3	COPPER ALLOY	Au PLATING OVER Ni AT CONTACT AREA Ni AT SOLDER AREA	
①	HOUSING	1	THERMOPLASTIC UL94V-0 COLOR: BLACK		

GENERAL TOLERANCE	DWG NO.	JYS	APPD:	WMD	Scale
X±0.45	X±1.5°	JYS	JYS	JYS	1:1
X±0.35	X±1.2°	BATTERY 3PIN 2.50PITCH 6.5H 有柱	CHKD:		UNIT
.XX±0.25	.XX±1.1°	JYS-BV650-067	DR:		mm
.XXX±0.15	.XXX±0.5°	Date	2012/02/29		
SHEET 1/1					

JYS 杰宇森电子有限公司  
JIE YU SEN ELECTRONIC CO., LTD.