

REV.	ECN.NO.	MODIFY.CONTENT	DATE
A		NEW	2011/10/31

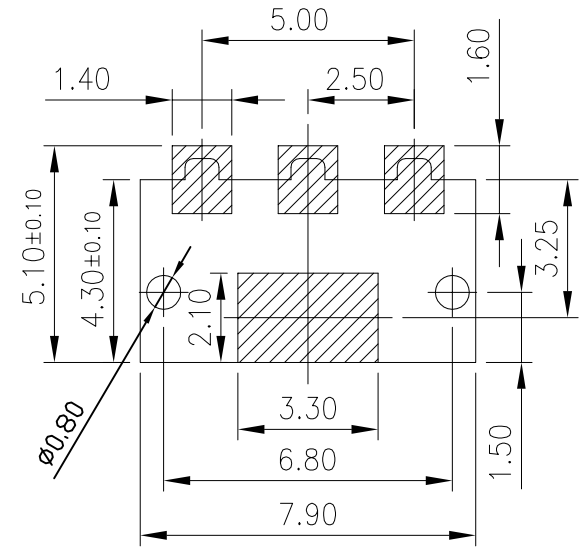

RECOMMENDED PCB LAYOUT  
TOP VIEW(. XX±0.05)

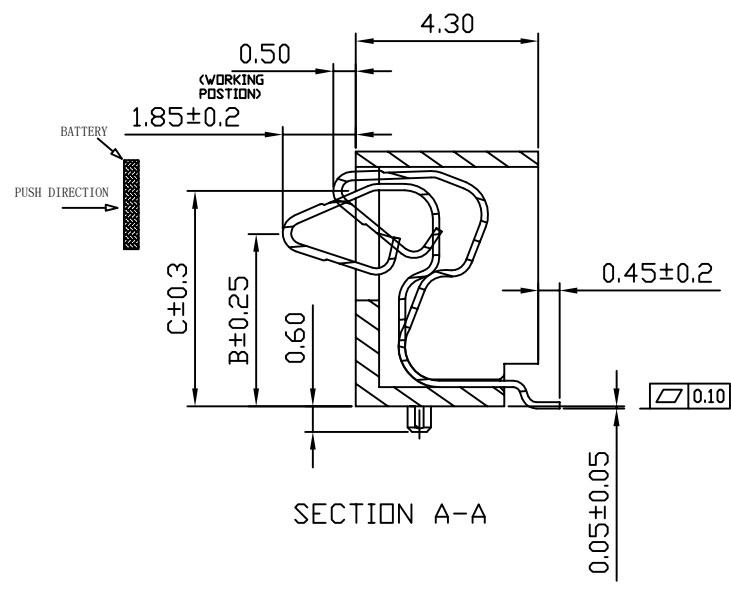
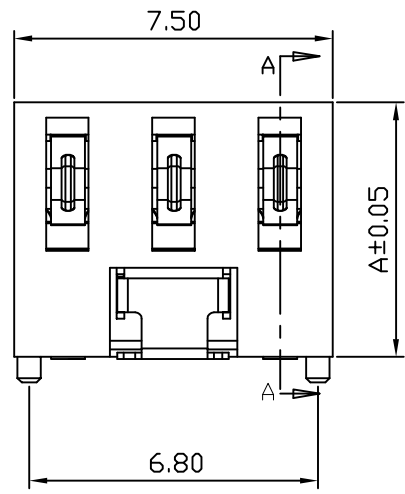
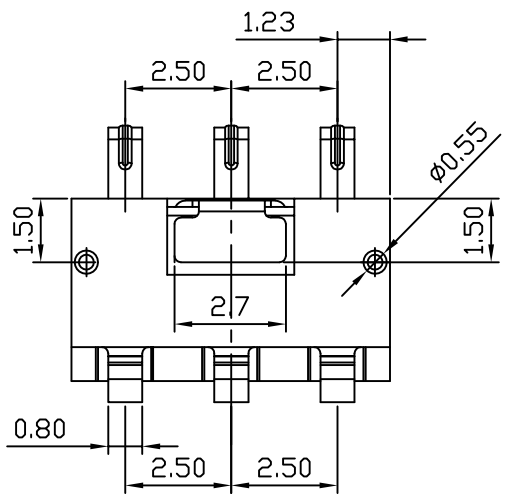

PART NO.	A	B	C
JYS-BY540-055B	5.4	3.8	4.6
JYS-BY600-056B	6.0	4.4	5.2
JYS-BY650-057B	6.5	4.9	5.7
JYS-BY700-058B	7.0	5.4	6.2
JYS-BY750-059B	7.5	5.9	6.7
JYS-BY800-060B	8.0	6.4	7.2

性能:  
 额定电流: 2.0A  
 额定电压: 12V  
 耐电压: 500V  
 接触电阻: 30mΩ  
 绝缘电阻: 500MΩ  
 工作温度: -40℃~+85℃  
 塑件(材质): LCP  
 接触点(材质): 磷铜, 镀金

GENERAL TOLERANCE		DWG NO.	JYSA0405-04	APPD:	WIND	Scale	1:1
X.±0.45	x.*±5'	Title	BATTERY 3PIN 2.50PITCH 5.4H-8.0H WITH POST	CHKD:		UNIT	mm
.X±0.35	.x.*±2'			DR:			
.XX±0.25	.xx.*±1'	Part NO.	SEE TABLE	Date	2012/02/29		
.XXX±0.15	.xxx.*±0.5'			Shenzhen <b>JYSCONN Electronics Co., LTD.</b>			
SHEET	1/1						